

# Kitchen faucet TOSCANA-33

Product information



## Description

Refined classics, which was created for pleasure and comfort.

- 5-years warranty
- After assembly all our faucets are being 100% tested
- Durable and glossy surface on all our faucets. We use more durable coating for shine and long-term use of faucets, which is more resistant to scratches, dents, limescale, rust.
- High-quality brass with lowered content of harmful impurities is one of the most important component materials.
- Faucets with the ANTI-NOISE system work silently and do not cause discomfort.
- Air and water mixing technology ensures exceptional economy.
- Aerator Neoperl® Honeycomb – ensures longlasting, quiet and flawless performance of the faucet.
- Ceramic valve with 180 rotation angle and noise absorber. It ensures long-lasting, silent and smooth functioning.
- Faucet is complemented with 40 cm connection hoses.



## Specification

<b>Code</b>	M8L006
<b>Intended use</b>	Kitchen faucet
<b>EAN</b>	4779035273227
<b>Warranty</b>	5
<b>Series</b>	Toscana
<b>Segment</b>	Extra
<b>Connection</b>	1/2
<b>Finish</b>	Chrome plated
<b>Debit l/m</b>	13.5

## Components



618040



664028



636739

EAN: 4779028804469 EAN: 4779035271742 EAN: 4779035274385

## Scheme

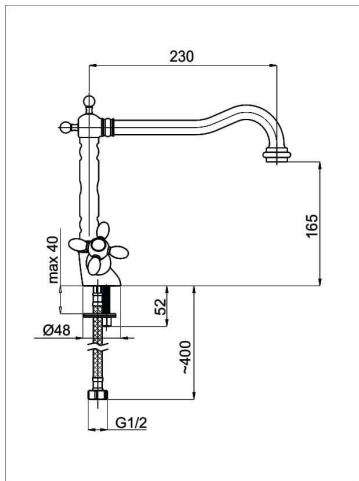

## Package



Package quantity	9
Weight Brutto (kg)	1.966
Weight Netto (kg)	1.529
1 package length (m)	0.065
1 packaging depth (m)	0.366
The primary package width (m)	0.266
2 package weight (kg)	1.04
2 packaging capacity	0.06772
2 Packaging depth (m)	0.22
2 packaging length (m)	0.81
2 packaging width (m)	0.38